

Table of Contents

Introduction	2
AC Motors	4
Force and Motion	6
AC Motor Construction	14
Magnetism	20
Electromagnetism	22
Developing a Rotating Magnetic Field	28
Rotor Rotation.....	34
Motor Specifications.....	39
NEMA Motor Characteristics.....	43
Derating Factors	51
AC Motors and AC Drives.....	53
Matching AC Motors to the Load	58
Enclosures	63
Mounting	67
Siemens Motors	74
Above NEMA Motors	79
Review Answers.....	84
Final Exam	85

Introduction

Welcome to another course in the STEP series, **Siemens Technical Education Program**, designed to prepare our distributors to sell Siemens Energy & Automation products more effectively. This course covers **Basics of AC Motors** and related products.

Upon completion of **Basics of AC Motors** you should be able to:

- Explain the concepts of force, inertia, speed, and torque
- Explain the difference between work and power
- Describe the construction of a squirrel cage AC motor
- Describe the operation of a rotating magnetic field
- Calculate synchronous speed, slip, and rotor speed
- Plot starting torque, accelerating torque, breakdown torque, and full-load torque on a NEMA torque curve
- Apply derating factors as required by an application
- Describe the relationship between V/Hz, torque, and horsepower
- Match an AC motor to an application and its load
- Identify NEMA enclosures and mounting configurations
- Describe Siemens Medallion™, PE-21 Plus™, vertical pump, and IEC motors
- Describe torque characteristics and enclosures of Siemens above NEMA motors

This knowledge will help you better understand customer applications. In addition, you will be better able to describe products to customers and determine important differences between products. You should complete **Basics of Electricity** before attempting **Basics of AC Motors**. An understanding of many of the concepts covered in **Basics of Electricity** is required for **Basic of AC Motors**. You may also want to complete **Basics of Control Components** which discusses the application of control devices for start, stop, and thermal protection of AC motors.

If you are an employee of a Siemens Energy & Automation authorized distributor, fill out the final exam tear-out card and mail in the card. We will mail you a certificate of completion if you score a passing grade. Good luck with your efforts.

Medallion and PE-21 Plus are trademarks of Siemens Energy & Automation, Inc.

National Electrical Code[®] and NEC[®] are registered trademarks of the National Fire Protection Association, Quincy, MA 02269. Portions of the National Electrical Code are reprinted with permission from NFPA 70-2002, National Electrical Code Copyright, 2001, National Fire Protection Association, Quincy, MA 02269. This reprinted material is not the complete and official position of the National Fire Protection Association on the referenced subject which is represented by the standard in its entirety.

Underwriters Laboratories Inc. is a registered trademark of Underwriters Laboratories Inc., Northbrook, IL 60062. The abbreviation "UL" shall be understood to mean Underwriters Laboratories Inc.

National Electrical Manufacturers Association is located at 2101 L. Street, N.W., Washington, D.C. 20037. The abbreviation "NEMA" is understood to mean National Electrical Manufacturers Association.

AC Motors

AC motors are used worldwide in many residential, commercial, industrial, and utility applications. Motors transform electrical energy into mechanical energy. An AC motor may be part of a pump or fan, or connected to some other form of mechanical equipment such as a winder, conveyor, or mixer. AC motors are found on a variety of applications from those that require a single motor to applications requiring several motors. Siemens manufactures a wide variety of motors for various applications. The material presented in this course will help in selection of a motor for a specific application.

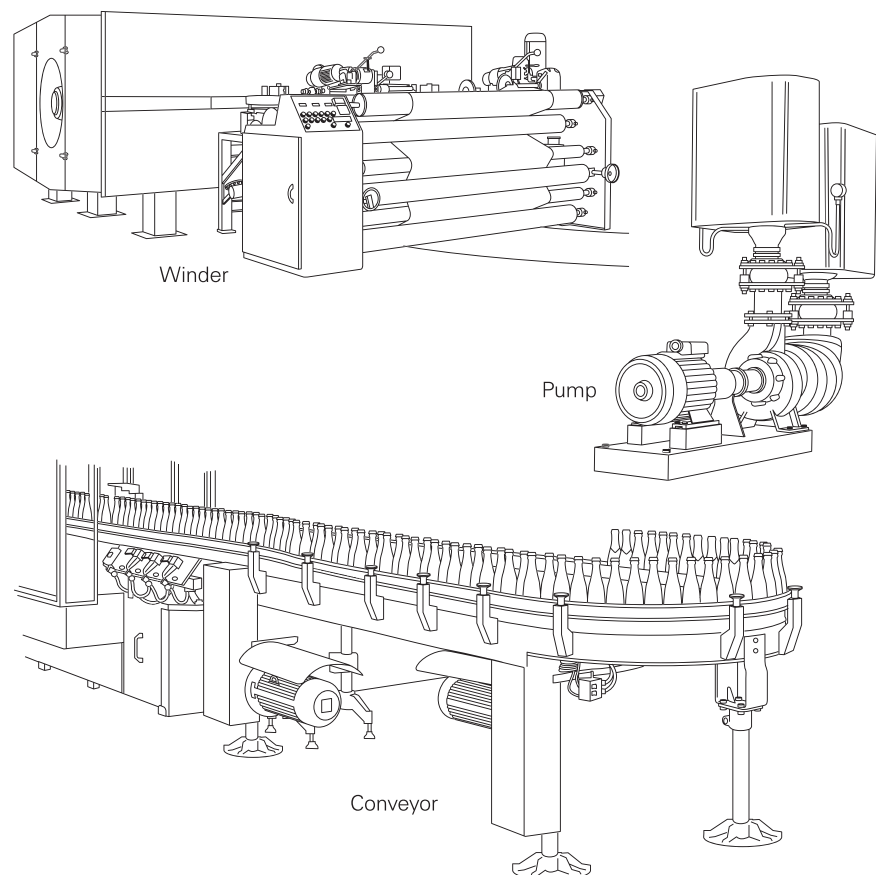

NEMA

Throughout this course reference is made to the National Electrical Manufacturers Association (NEMA). NEMA sets standards for a wide range of electrical products, including motors. NEMA is primarily associated with motors used in North America. The standards developed represent general industry practices and are supported by manufacturers of electrical equipment. These standards can be found in NEMA Standard Publication No. MG 1. Some large AC motors may not fall under NEMA standards. These motors are built to meet the requirements of a specific application. These are referred to as above NEMA motors.



IEC

The International Electrotechnical Commission (IEC) is another organization responsible for motor standards. IEC standards are a group of recommended electrical practices developed by committees from participating IEC countries. These standards are different than NEMA standards. IEC standards are associated with motors used in many countries, including motors used in North America. These standards can be found in IEC 34-1-16. Motors which meet or exceed these standards are referred to as IEC motors.

Force and Motion

Before discussing AC motors it is necessary to understand some of the basic terminology associated with motor operation. Many of these terms are familiar to us in some other context. Later in the course we will see how these terms apply to AC motors.

Force

In simple terms, a force is a push or a pull. Force may be caused by electromagnetism, gravity, or a combination of physical means.

Net force

Net force is the vector sum of all forces that act on an object, including friction and gravity. When forces are applied in the same direction they are added. For example, if two 10 pound forces are applied in the same direction the net force would be 20 pounds.

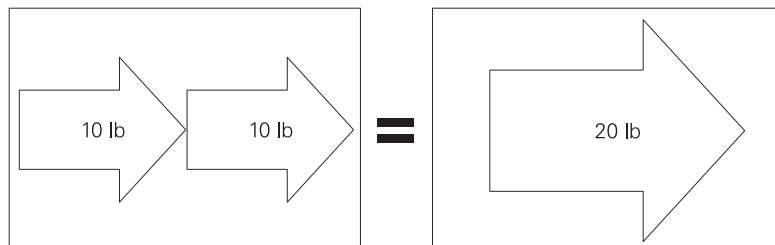

If 10 pounds of force is applied in one direction and 5 pounds of force is applied in the opposite direction, the net force would be 5 pounds and the object would move in the direction of the greater force.

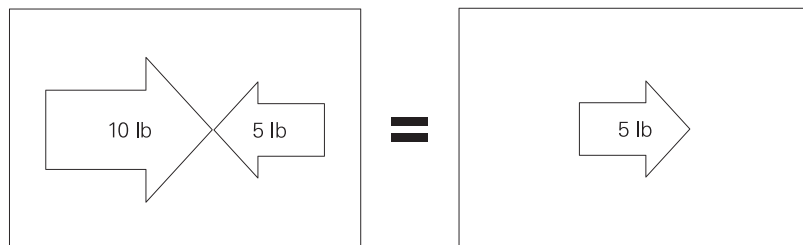

If 10 pounds of force is applied equally in both directions, the net force would be zero and the object would not move.

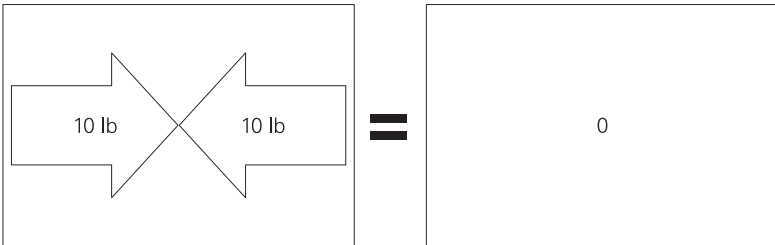

Torque

Torque is a twisting or turning force that causes an object to rotate. For example, a force applied to the end of a lever causes a turning effect or torque at the pivot point.

Torque (τ) is the product of force and radius (lever distance).

$$\tau = \text{Force} \times \text{Radius}$$

In the English system torque is measured in pound-feet (lb-ft) or pound-inches (lb-in). For example, if 10 lbs of force is applied to a lever 1 foot long the resulting torque would be 10 lb-ft.

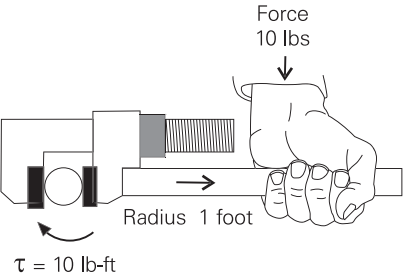

An increase in force or radius would result in a corresponding increase in torque. Increasing the radius to two feet, for example, results in 20 lb-ft of torque.

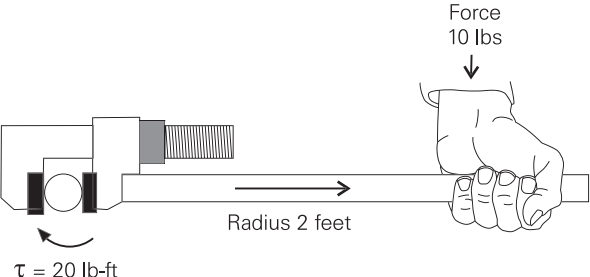

Speed

An object in motion travels a distance in a given time. Speed is the ratio of the distance traveled and the time it takes to travel the distance.

$$\text{Speed} = \frac{\text{Distance}}{\text{Time}}$$

Linear Speed

The linear speed of an object determines how long it takes the object to get from point A to point B. Linear speed is usually expressed in a form that combines units of distance divided by units of time such as meters per second (m/s). For example, if the distance between point A and point B were 10 meters, and it took 2 seconds to travel the distance, the speed would be 5 m/s.



Angular (Rotational) Speed

The angular speed of a rotating object determines how long it takes a given point on the object to make one complete revolution from its starting point. Angular speed is often expressed in revolutions per minute (RPM). An object that makes ten complete revolutions in one minute, for example, has a speed of 10 RPM.

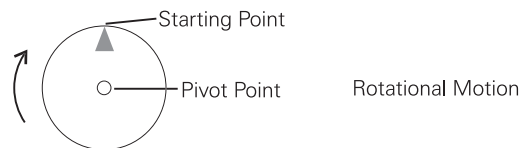

Acceleration

An object can change speed. An increase in speed is called acceleration. Acceleration occurs only when there is a change in the force acting upon the object. An object can also change from a higher to a lower speed. This is known as deceleration (negative acceleration). A rotating object, for example, can accelerate from 10 RPM to 20 RPM, or decelerate from 20 RPM to 10 RPM.

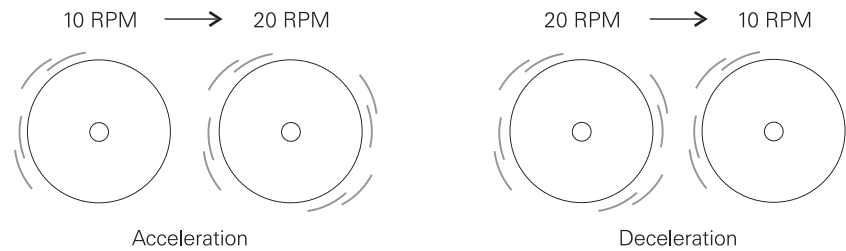

Inertia

Mechanical systems are subject to the law of inertia. The law of inertia states that an object will tend to remain in its current state of rest or motion unless acted upon by an external force. This property of resistance to acceleration/deceleration is referred to as the moment of inertia. The English system of measurement is pound-feet squared (lb-ft^2).

If we look at a continuous roll of paper, for example, we know that when the roll is stopped it would take a certain amount of force to overcome the inertia of the roll to get it rolling. The force required to overcome this inertia can come from a source of energy such as a motor. Once rolling, the paper will continue unwinding until another force acts on it to bring it to a stop.

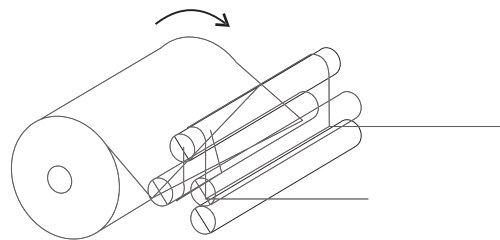

Friction

Any system in motion has losses that drain energy from the system. The law of inertia is still valid, however, because the system will remain in motion at constant speed if energy is added to the system to compensate for the losses. In the previous illustration, for example, these losses include:

- Friction applied to motor and driven equipment bearings
- Wind losses in the motor and driven equipment
- Friction between material on winder and rollers

Work

Whenever a force of any kind causes motion, work is accomplished. For example, work is accomplished when an object on a conveyor is moved from one point to another.

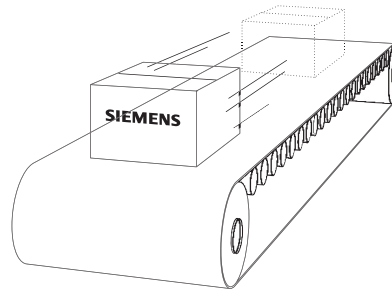

Work is generally expressed in foot-pounds and is defined by the product of the net force (F) applied and the distance (d) moved. If twice the force is applied, twice the work is done. If an object moves twice the distance, twice the work is done.

$$W = F \times d$$

Power

Power is the rate of doing work, or work divided by time.

$$\text{Power} = \frac{\text{Force} \times \text{Distance}}{\text{Time}}$$

$$\text{Power} = \frac{\text{Work}}{\text{Time}}$$

In other words, power is the amount of work it takes to move the package from one point to another point, divided by the time.

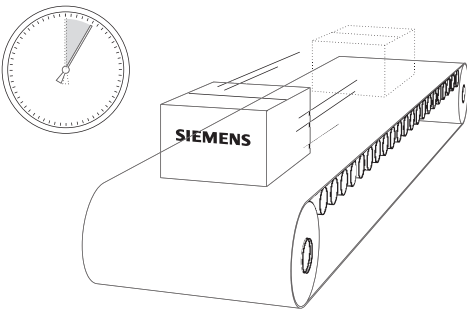

Horsepower

Power can be expressed in foot-pounds per second, but is often expressed in horsepower (HP). This unit was defined in the 18th century by James Watt. Watt sold steam engines and was asked how many horses one steam engine would replace. He had horses walk around a wheel that would lift a weight. He found that a horse would average about 550 foot-pounds of work per second. One horsepower is equivalent to 550 foot-pounds per second or 33,000 foot-pounds per minute.

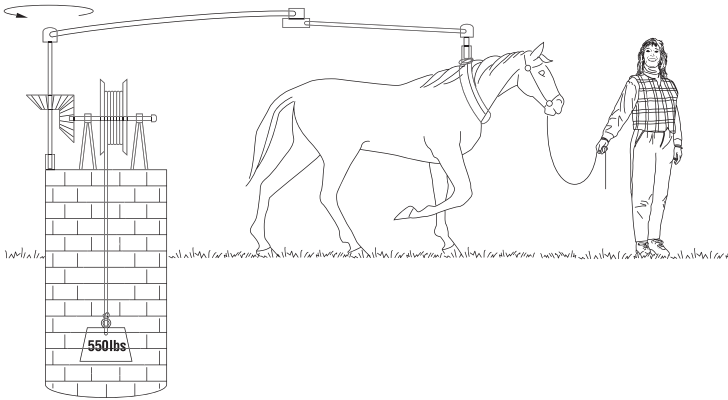

The following formula can be used to calculate horsepower when torque (in lb-feet) and speed are known. An increase of torque, speed, or both will cause an increase in horsepower.

$$HP = \frac{T \times RPM}{5250}$$

Horsepower and Kilowatts

AC motors manufactured in the United States are generally rated in horsepower (HP). Equipment manufactured in Europe is generally rated in kilowatts (KW). Horsepower can be converted to kilowatts with the following formula:

$$KW = .746 \times HP$$

For example, a 25 HP motor is equivalent to 18.65 KW.

$$18.65 \text{ KW} = .746 \times 25 \text{ HP}$$

Kilowatts can be converted to horsepower with the following formula:

$$HP = 1.341 \times KW$$

The power formula for a single-phase system is:

$$KW = \frac{V \times I \times PF}{1000}$$

The power formula for three-phase power is:

$$KW = \frac{V \times I \times PF \times 1.732}{1000}$$

Review 1

1. A _____ is a push or a pull.
2. An object has 20 pounds of force applied in one direction and 5 pounds of force applied in the opposite direction. The net force is _____ pounds.
3. A twisting or turning force that causes an object to rotate is known as _____ .
4. If 40 pounds of force were applied to a lever 2 feet long, the torque would be _____ lb-ft.
5. The law of _____ states that an object will tend to remain in its current state of rest or motion unless acted upon by an external force.
6. _____ is the ratio of distance traveled and time.
7. The speed of a rotating object is generally given in _____ per _____ .
8. _____ occurs when there is an increase in an object's speed.

AC Motor Construction

AC induction motors are commonly used in industrial applications. The following motor discussion will center around three-phase, 460 VAC, asynchronous, induction motors. An asynchronous motor is a type of motor where the speed of the rotor is less than the speed of the rotating magnetic field. This type of motor is illustrated below. The three basic parts of an AC motor are the rotor, stator, and enclosure.

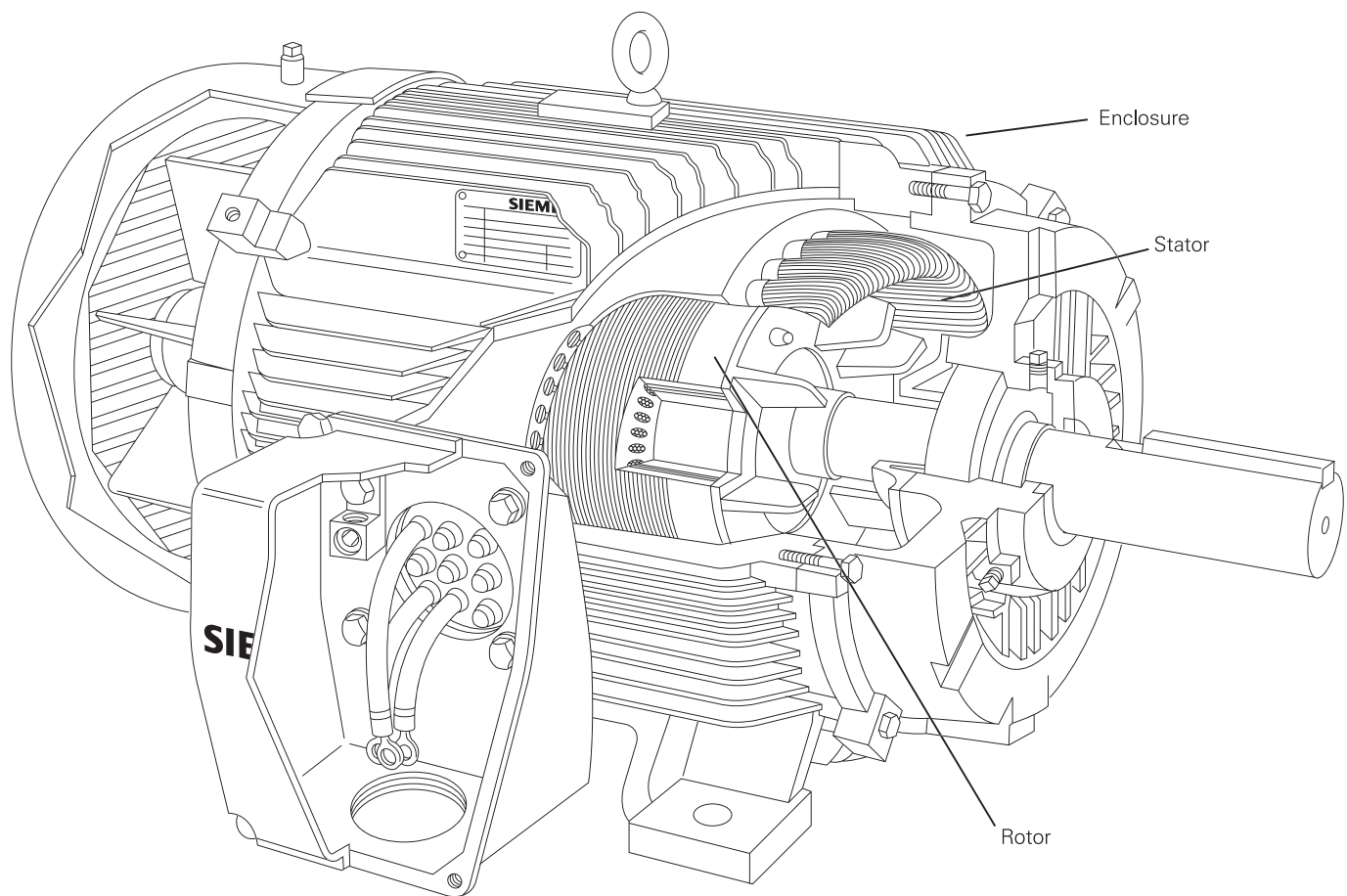

Stator Construction

The stator and the rotor are electrical circuits that perform as electromagnets. The stator is the stationary electrical part of the motor. The stator core of a NEMA motor is made up of several hundred thin laminations.

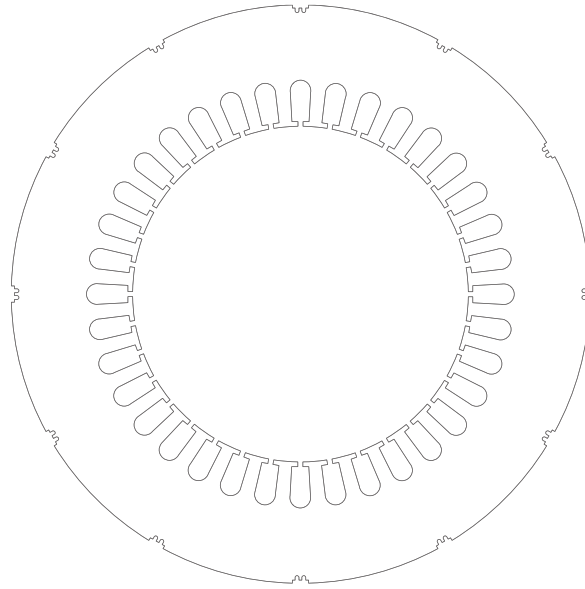

Stator Windings

Stator laminations are stacked together forming a hollow cylinder. Coils of insulated wire are inserted into slots of the stator core.

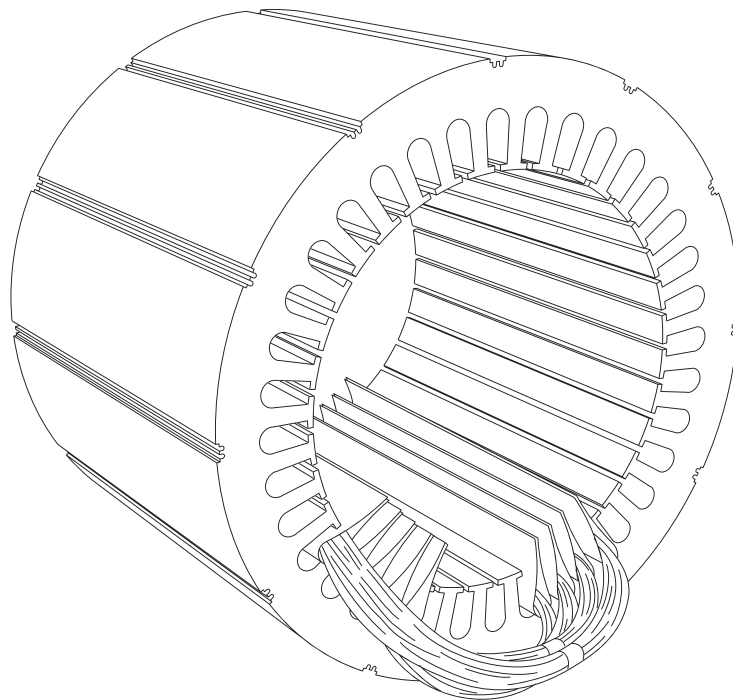

Each grouping of coils, together with the steel core it surrounds, form an electromagnet. Electromagnetism is the principle behind motor operation. The stator windings are connected directly to the power source.

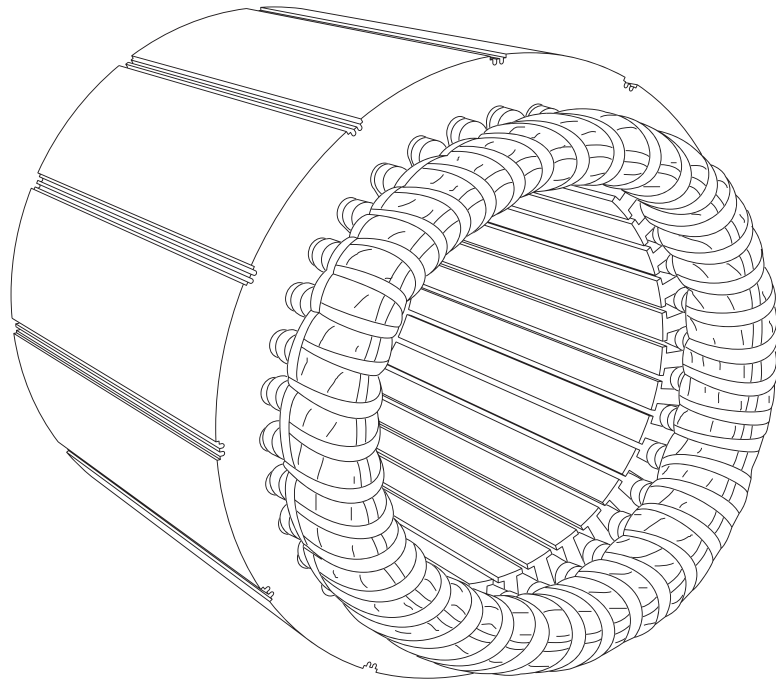

Rotor Construction

The rotor is the rotating part of the electromagnetic circuit. The most common type of rotor is the "squirrel cage" rotor. Other types of rotor construction will be mentioned later in the course. The construction of the squirrel cage rotor is reminiscent of rotating exercise wheels found in cages of pet rodents.

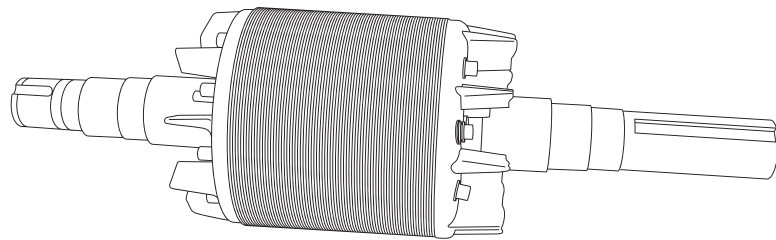

The rotor consists of a stack of steel laminations with evenly spaced conductor bars around the circumference.

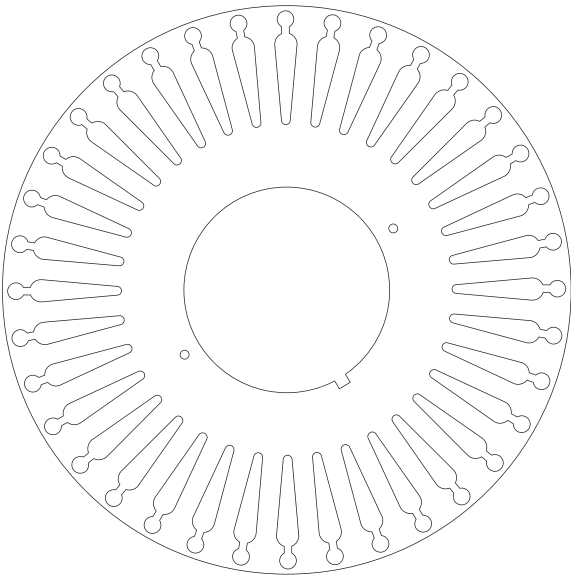

The laminations are stacked together to form a rotor core. Aluminum is die cast in the slots of the rotor core to form a series of conductors around the perimeter of the rotor. The conductor bars are mechanically and electrically connected with end rings. The rotor core mounts on a steel shaft to form a rotor assembly.

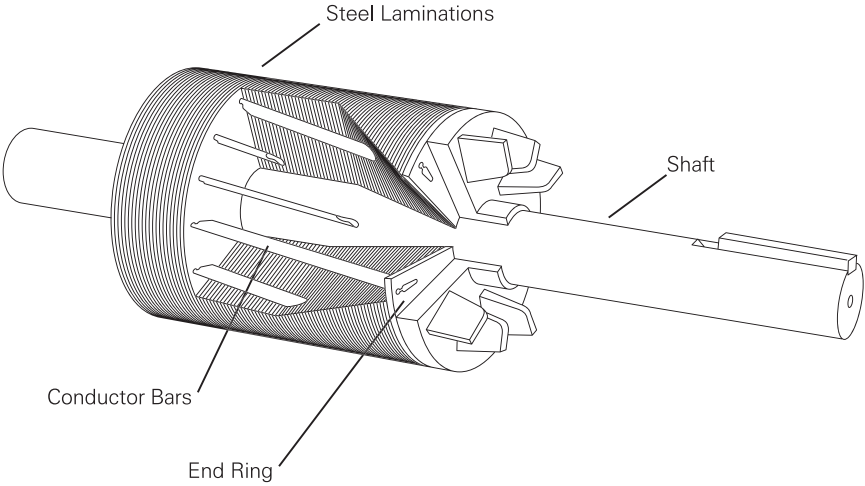

Enclosure

The enclosure consists of a frame (or yoke) and two end brackets (or bearing housings). The stator is mounted inside the frame. The rotor fits inside the stator with a slight air gap separating it from the stator. There is no direct physical connection between the rotor and the stator.

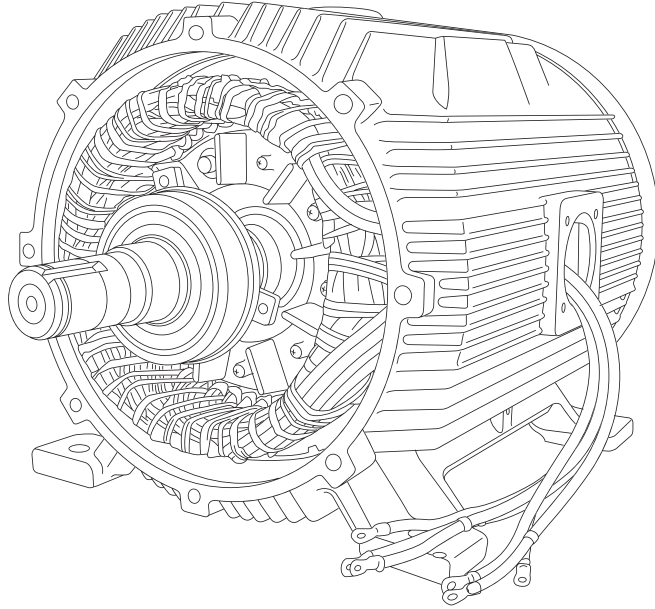

The enclosure also protects the electrical and operating parts of the motor from harmful effects of the environment in which the motor operates. Bearings, mounted on the shaft, support the rotor and allow it to turn. A fan, also mounted on the shaft, is used on the motor shown below for cooling.

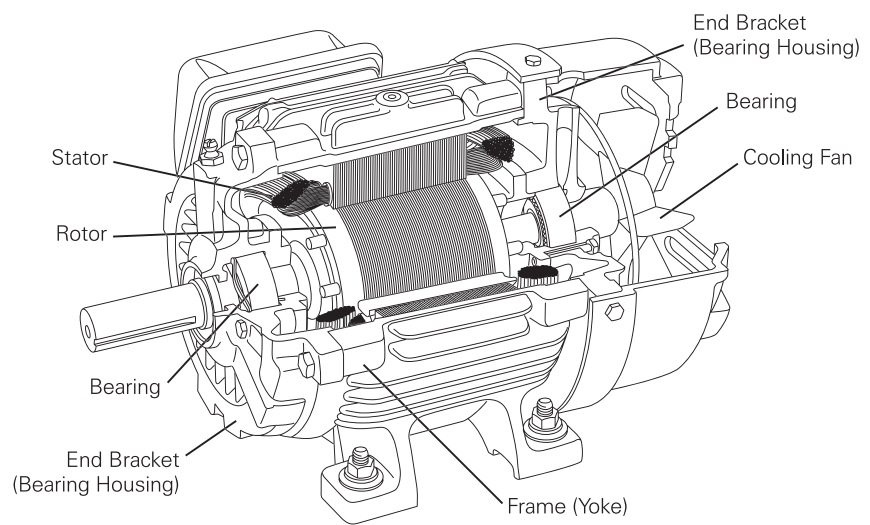

Review 2

1. Identify the following components from the illustration:

A. _____

B. _____

C. _____

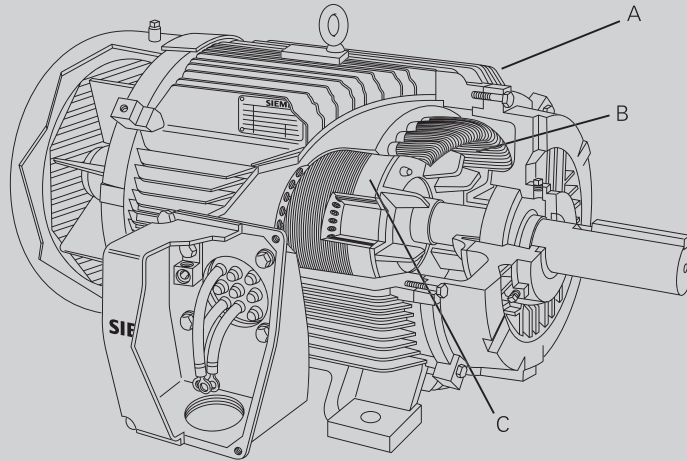

2. The _____ and the _____ are two parts of an electrical circuit that form an electromagnet.

3. The _____ is the stationary electrical part of an AC motor.

4. The _____ is the rotating electrical part of an AC motor.

5. The _____ _____ rotor is the most common type of rotor used in AC motors.

Magnetism

The principles of magnetism play an important role in the operation of an AC motor. All magnets have two characteristics. They attract and hold metal objects like steel and iron. If free to move, like the compass needle, the magnet will assume roughly a north-south position.

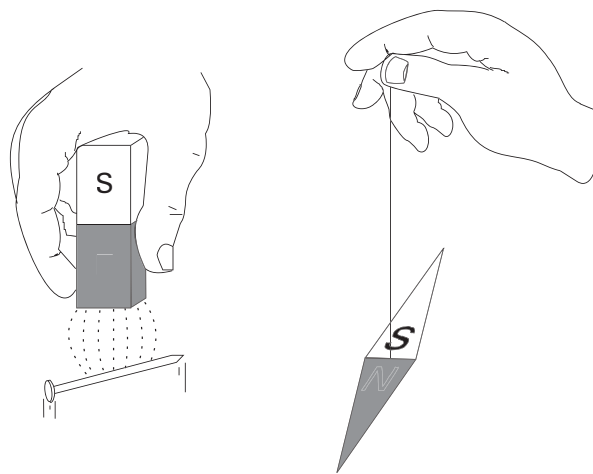

Magnetic Lines of Flux

We know that a magnet attracts an iron or steel object by an invisible force. The magnet's invisible force is called lines of flux. These lines of flux make up an invisible magnetic field. Every magnet has two poles, one north pole and one south pole. Invisible magnetic lines of flux leave the north pole and enter the south pole. While the lines of flux are invisible, the effects of magnetic fields can be made visible. When a sheet of paper is placed on a magnet and iron filings loosely scattered over it, the filings will arrange themselves along the invisible lines of flux.

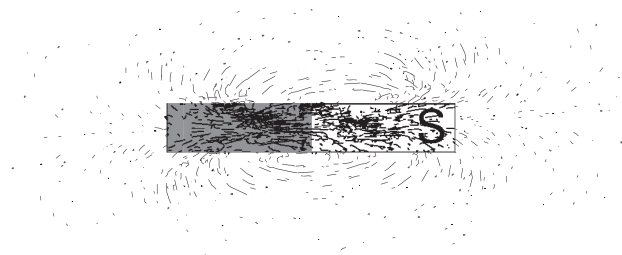

By drawing lines the way the iron filings have arranged themselves, the following illustration is obtained. Magnetic lines of flux always form closed loops, leaving the north pole and entering the south pole. They return to the north pole through the magnet.

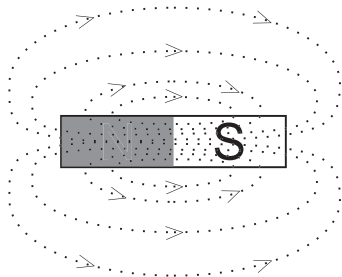

Unlike Poles Attract

The polarity of the magnetic field affects the interaction between magnets. For example, when the opposite poles of two magnets are brought within range of each other the lines of flux combine and tend to pull or attract the magnets.

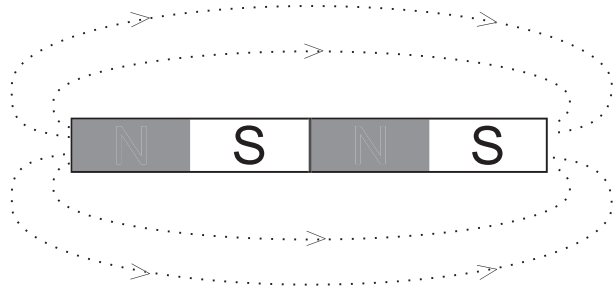

Like Poles Repel

When poles of like polarity of two magnets are brought within range of each other the lines of flux produce a force that tends to push or repel the magnets. For this reason it is said that unlike poles attract and like poles repel. The attracting and repelling action of the magnetic fields is important in the operation of AC motors.

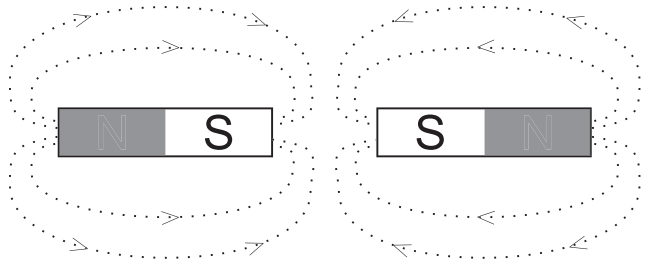

Electromagnetism

When current flows through a conductor a magnetic field is produced around the conductor. The magnetic field is made up of lines of flux, just like a natural magnet. The size and strength of the magnetic field will increase and decrease as the current flow strength increases and decreases.

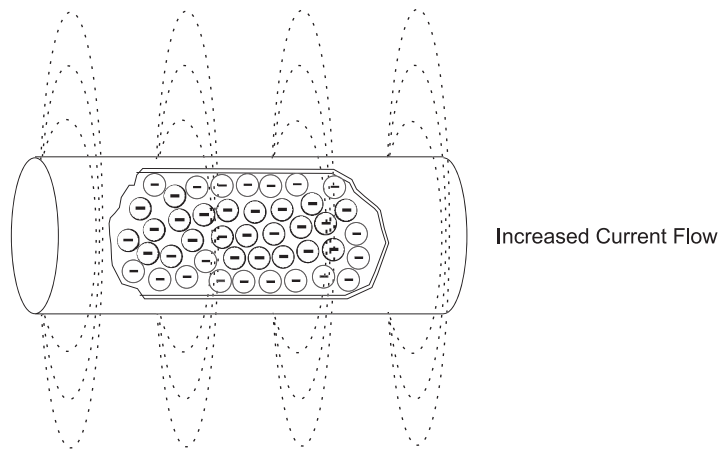
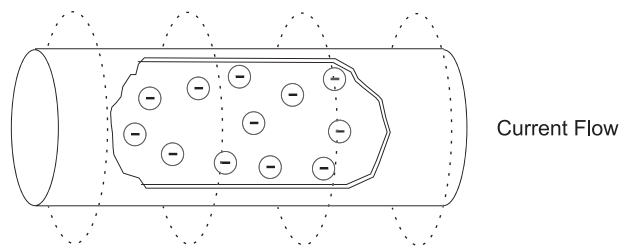

Left-Hand Rule for Conductors

A definite relationship exists between the direction of current flow and the direction of the magnetic field. The left-hand rule for conductors demonstrates this relationship. If a current-carrying conductor is grasped with the left hand with the thumb pointing in the direction of electron flow, the fingers will point in the direction of the magnetic lines of flux.

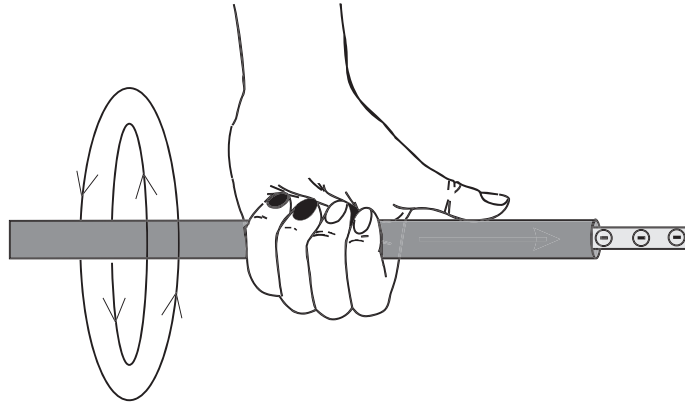

In the following illustration it can be seen that when the electron flow is away from the viewer (indicated by the plus sign) the lines of flux flow in a counterclockwise direction around the conductor. When the electron flow reverses and current flow is towards the viewer (indicated by the dot) the lines of flux reverse direction and flow in a clockwise direction.

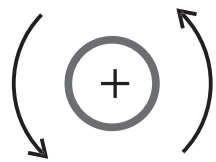

Current Flow
Away From View

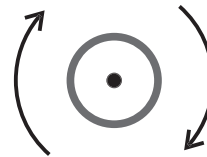

Current Flow
Toward View

Electromagnet

An electromagnet can be made by winding the conductor into a coil and applying a DC voltage. The lines of flux, formed by current flow through the conductor, combine to produce a larger and stronger magnetic field. The center of the coil is known as the core. In this simple electromagnet the core is air.

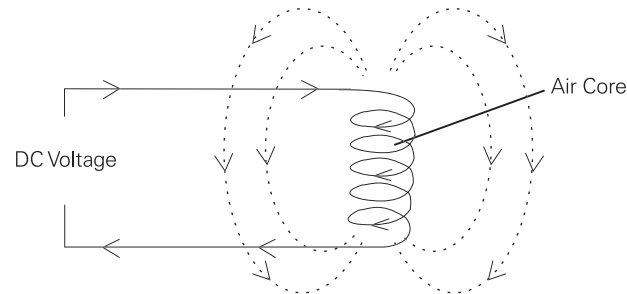

Adding an Iron Core

Iron is a better conductor of flux than air. The air core of an electromagnet can be replaced by a piece of soft iron. When a piece of iron is placed in the center of the coil more lines of flux can flow and the magnetic field is strengthened.

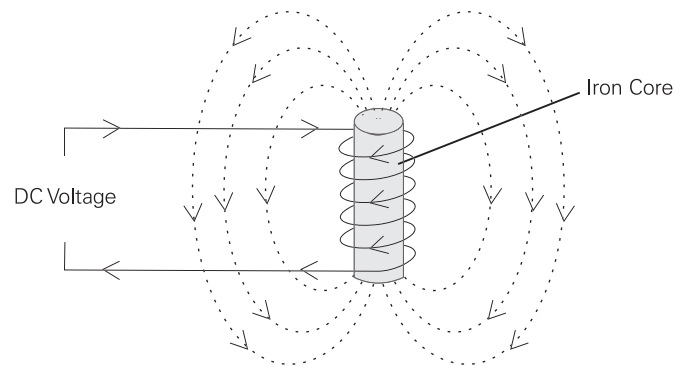

Number of Turns

The strength of the magnetic field in the DC electromagnet can be increased by increasing the number of turns in the coil. The greater the number of turns the stronger the magnetic field.

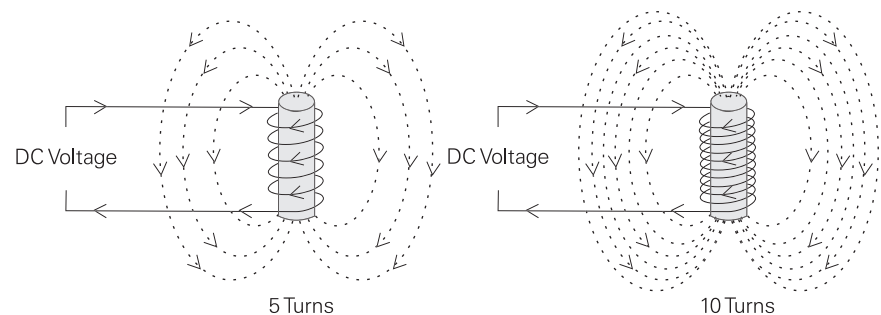

Changing Polarity

The magnetic field of an electromagnet has the same characteristics as a natural magnet, including a north and south pole. However, when the direction of current flow through the electromagnet changes, the polarity of the electromagnet changes. The polarity of an electromagnet connected to an AC source will change at the same frequency as the frequency of the AC source. This can be demonstrated in the following illustration.

At Time 1 current flow is at zero. There is no magnetic field produced around the electromagnet. At Time 2 current is flowing in a positive direction. A magnetic field builds up around the electromagnet. The electromagnet assumes a polarity with the south pole on the top and the north pole on the bottom. At Time 3 current flow is at its peak positive value. The strength of the electromagnetic field is at its greatest value. At Time 4 current flow decreases and the magnetic field begins to collapse, until Time 5 when current flow and magnetic field are at zero. Current immediately begins to increase in the opposite direction. At Time 6 current is increasing in a negative direction. The polarity of the electromagnetic field has changed. The north pole is now on top and the south pole is on the bottom. The negative half of the cycle continues through Times 7 and 8, returning to zero at Time 9. This process will repeat 60 times a second with a 60 Hz AC power supply.

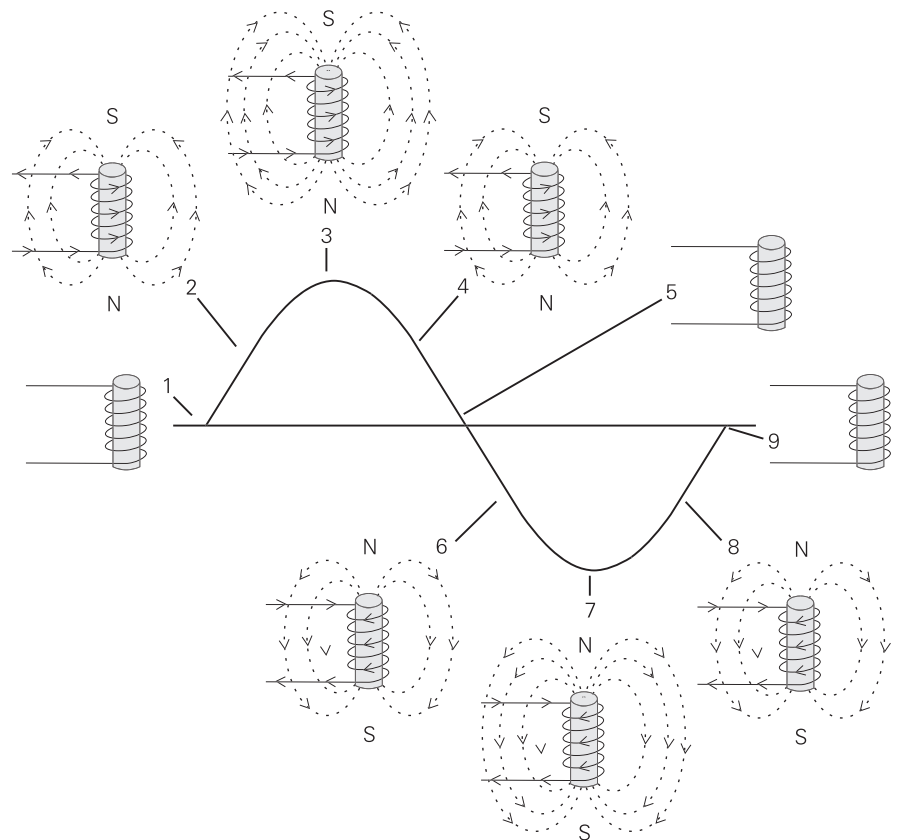

Induced Voltage

A conductor moving through a magnetic field will have a voltage induced into it. This electrical principle is used in the operation of AC induction motors. In the following illustration an electromagnet is connected to an AC power source. Another electromagnet is placed above it. The second electromagnet is in a separate circuit. There is no physical connection between the two circuits.

At Time 1 voltage and current are zero in both circuits. At Time 2 voltage and current are increasing in the bottom circuit. A magnetic field builds up in the bottom electromagnet. Lines of flux from the magnetic field building up in the bottom electromagnet cut across the top electromagnet. A voltage is induced in the top electromagnet and current flows through it. At Time 3 current flow has reached its peak. Maximum current is flowing in both circuits. The magnetic field around the coil continues to build up and collapse as the alternating current continues to increase and decrease. As the magnetic field moves through space, moving out from the coil as it builds up and back towards the coil as it collapses, lines of flux cut across the top coil. As current flows in the top electromagnet it creates its own magnetic field.

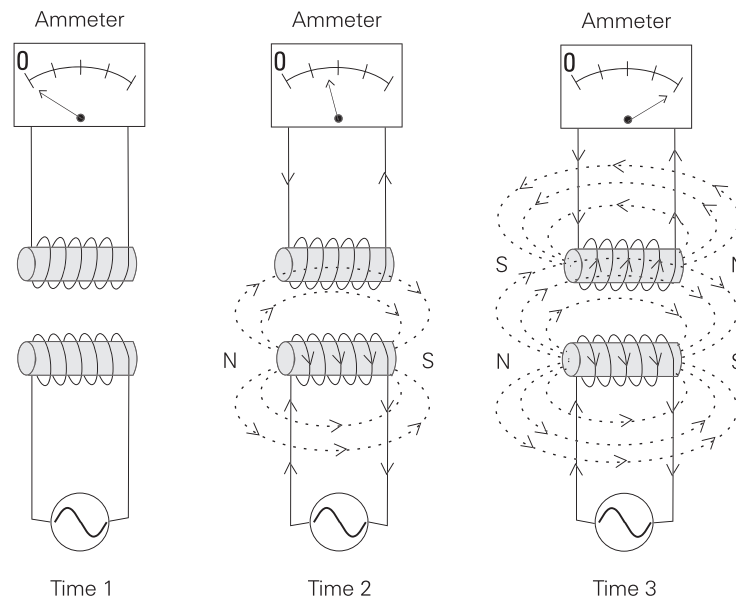

Electromagnetic Attraction

The polarity of the magnetic field induced in the top electromagnet is opposite the polarity of the magnetic field in the bottom electromagnet. Since opposite poles attract, the top electromagnet will follow the bottom electromagnet when it is moved.

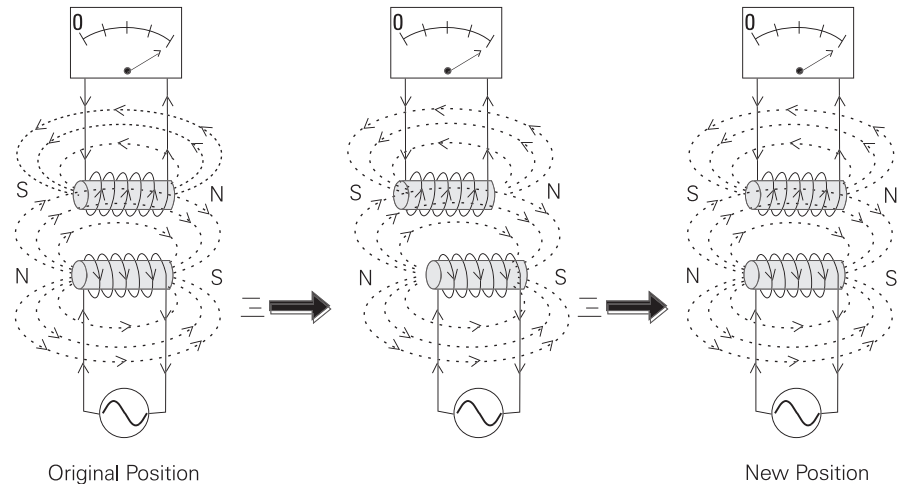

Review 3

- Magnetic lines of flux leave the _____ pole of a magnet and enter the _____ pole.
- In the following illustration, which magnets will attract each other and which magnets will repel each other?
 - | | |
|---|---|
| N | S |
|---|---|

N	S
---	---

 - | | |
|---|---|
| N | S |
|---|---|

S	N
---	---

 - | | |
|---|---|
| S | N |
|---|---|

N	S
---	---

 - | | |
|---|---|
| S | N |
|---|---|

S	N
---	---

- A _____ is produced around a conductor when current is flowing through it.
- Which of the following will not increase the strength of the magnetic field?
 - Increase the current flow
 - Increase the number of turns in a coil
 - Add an iron core to a coil
 - Increase AC power supply frequency

Developing a Rotating Magnetic Field

The principles of electromagnetism explain the shaft rotation of an AC motor. Recall that the stator of an AC motor is a hollow cylinder in which coils of insulated wire are inserted.

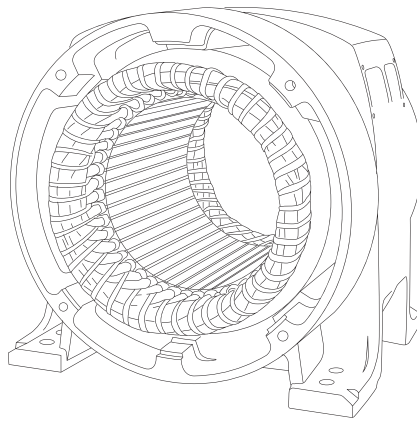

Stator Coil Arrangement

The following schematic illustrates the relationship of the coils. In this example six coils are used, two coils for each of the three phases. The coils operate in pairs. The coils are wrapped around the soft iron core material of the stator. These coils are referred to as motor windings. Each motor winding becomes a separate electromagnet. The coils are wound in such a way that when current flows in them one coil is a north pole and its pair is a south pole. For example, if A1 were a north pole then A2 would be a south pole. When current reverses direction the polarity of the poles would also reverse.

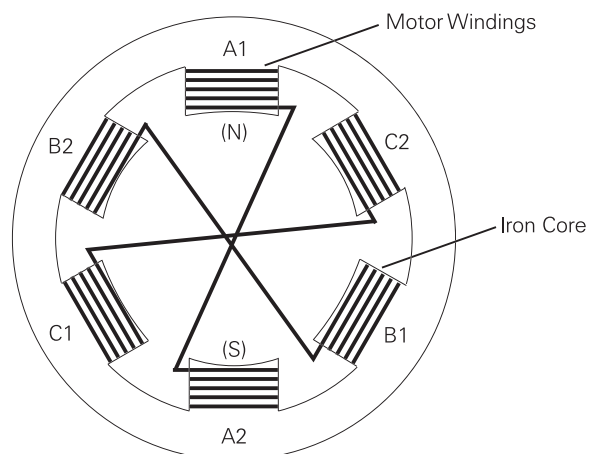

Power Supply

The stator is connected to a 3-phase AC power supply. In the following illustration phase A is connected to phase A of the power supply. Phase B and C would also be connected to phases B and C of the power supply respectively.

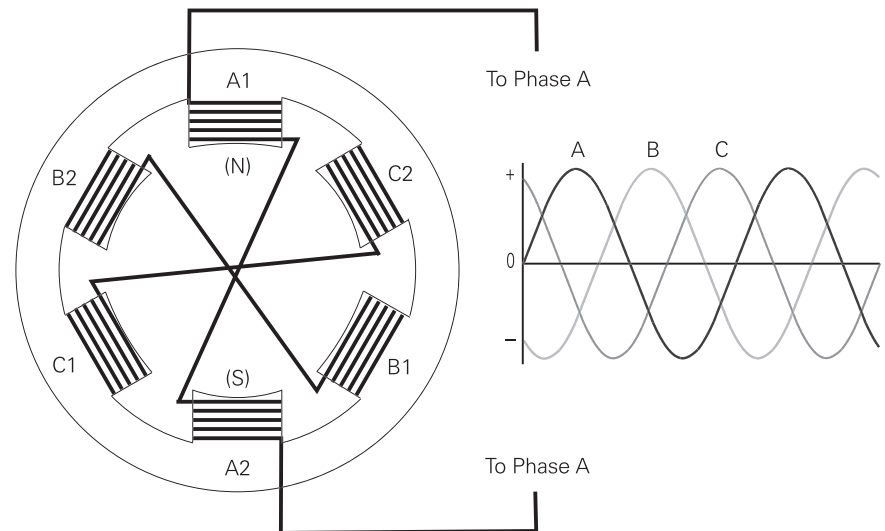

Phase windings (A, B, and C) are placed 120° apart. In this example, a second set of three-phase windings is installed. The number of poles is determined by how many times a phase winding appears. In this example, each phase winding appears two times. This is a two-pole stator. If each phase winding appeared four times it would be a four-pole stator.

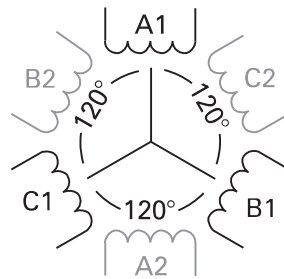

2-Pole Stator Winding

When AC voltage is applied to the stator, current flows through the windings. The magnetic field developed in a phase winding depends on the direction of current flow through that winding. The following chart is used here for explanation only. It will be used in the next few illustrations to demonstrate how a rotating magnetic field is developed. It assumes that a positive current flow in the A1, B1 and C1 windings result in a north pole.

Winding	Current Flow Direction	
	Positive	Negative
A1	North	South
A2	South	North
B1	North	South
B2	South	North
C1	North	South
C2	South	North

Start

It is easier to visualize a magnetic field if a start time is picked when no current is flowing through one phase. In the following illustration, for example, a start time has been selected during which phase A has no current flow, phase B has current flow in a negative direction and phase C has current flow in a positive direction. Based on the above chart, B1 and C2 are south poles and B2 and C1 are north poles. Magnetic lines of flux leave the B2 north pole and enter the nearest south pole, C2. Magnetic lines of flux also leave the C1 north pole and enter the nearest south pole, B1. A magnetic field results, as indicated by the arrow.

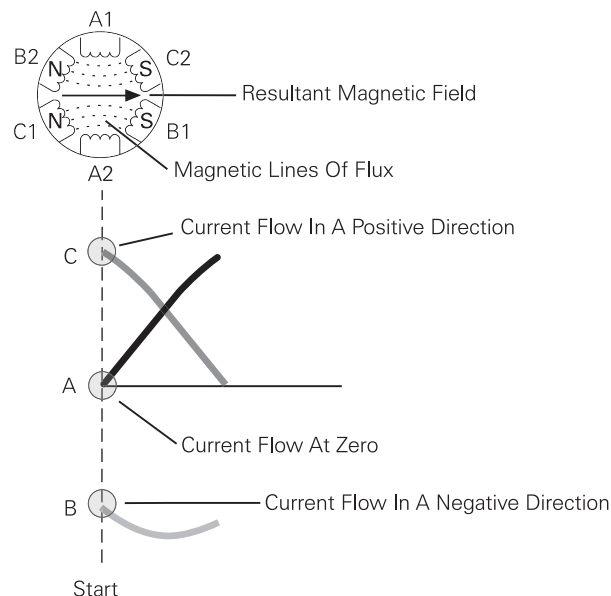

Time 1

If the field is evaluated at 60° intervals from the starting point, at Time 1, it can be seen that the field will rotate 60° . At Time 1 phase C has no current flow, phase A has current flow in a positive direction and phase B has current flow in a negative direction. Following the same logic as used for the starting point, windings A1 and B2 are north poles and windings A2 and B1 are south poles.

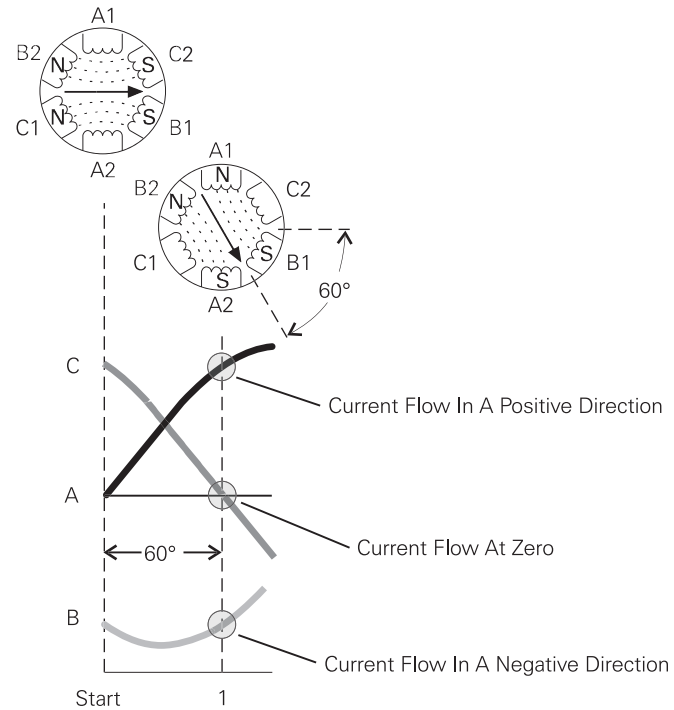

Time 2

At Time 2 the magnetic field has rotated 60° . Phase B has no current flow. Although current is decreasing in phase A it is still flowing in a positive direction. Phase C is now flowing in a negative direction. At start it was flowing in a positive direction. Current flow has changed directions in the phase C windings and the magnetic poles have reversed polarity.

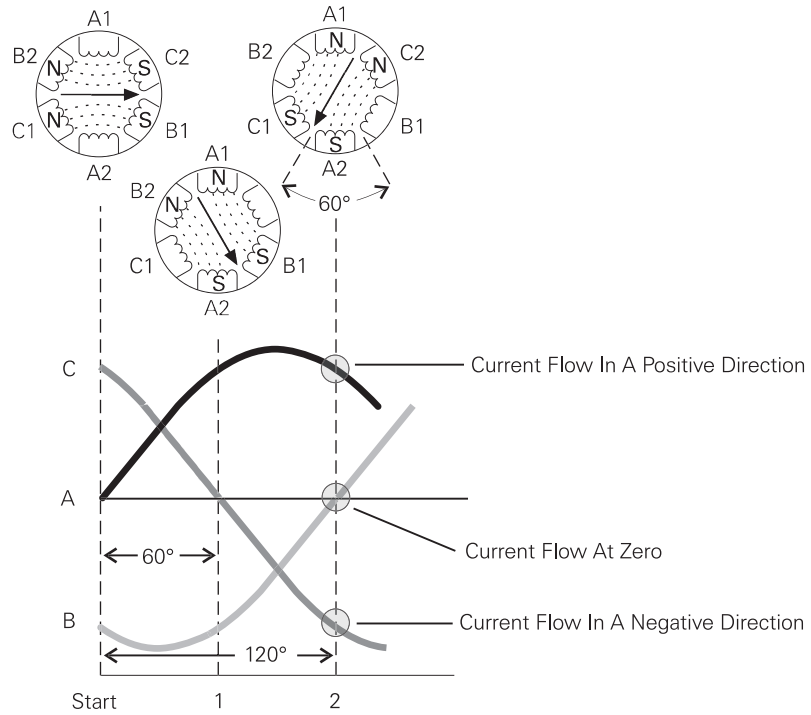

360° Rotation

At the end of six such time intervals the magnetic field will have rotated one full revolution or 360°. This process will repeat 60 times a second on a 60 Hz power supply.

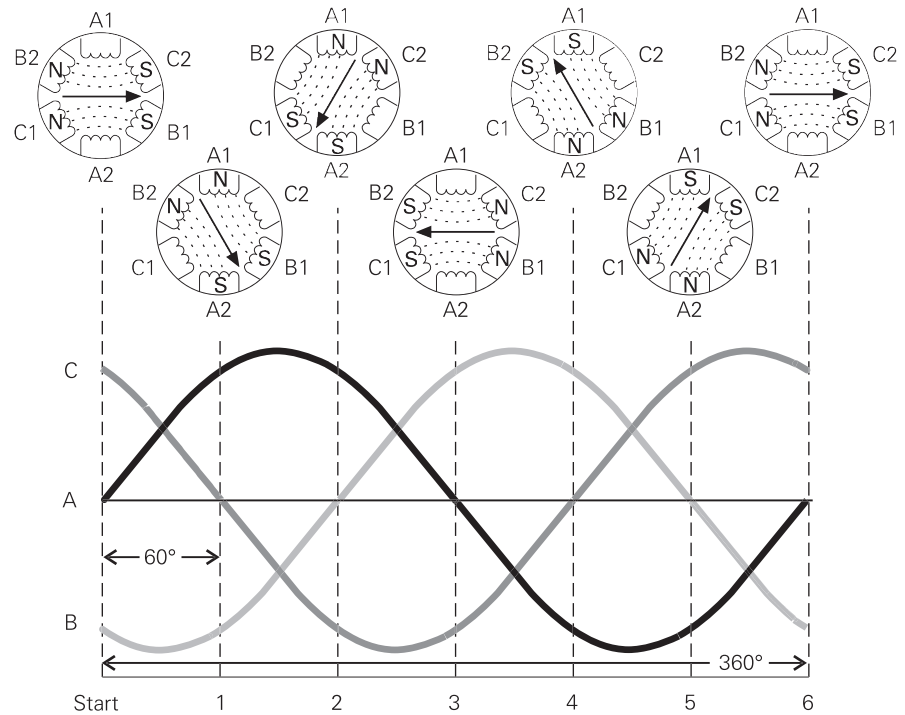

Synchronous Speed

The speed of the rotating magnetic field is referred to as synchronous speed (N_s). Synchronous speed is equal to 120 times the frequency (F), divided by the number of poles (P). The synchronous speed for a two-pole motor operated at 60 Hz, for example, is 3600 RPM.

$$N_s = \frac{120F}{P} \implies N_s = \frac{120 \times 60}{2} \implies N_s = 3600 \text{ RPM}$$

Synchronous speed decreases as the number of poles increase. The following table shows the synchronous speed at 60 Hz for the corresponding number of poles.

No. of Poles	Synchronous Speed
2	3600
4	1800
6	1200
8	900
10	720

Rotor Rotation

Permanent Magnet

To see how a rotor works, a magnet mounted on a shaft can be substituted for the squirrel cage rotor. When the stator windings are energized a rotating magnetic field is established. The magnet has its own magnetic field that interacts with the rotating magnetic field of the stator. The north pole of the rotating magnetic field attracts the south pole of the magnet, and the south pole of the rotating magnetic field attracts the north pole of the magnet. As the rotating magnetic field rotates, it pulls the magnet along causing it to rotate. This design, used on some motors, is referred to as a permanent magnet synchronous motor.

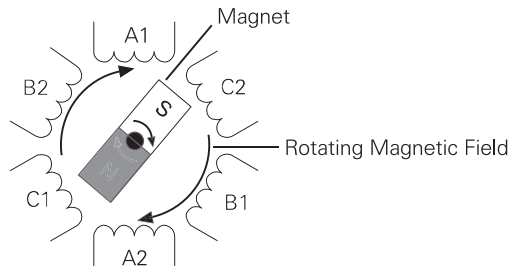

Induced Voltage Electromagnet

The squirrel cage rotor acts essentially the same as the magnet. When power is applied to the stator, current flows through the winding, causing an expanding electromagnetic field which cuts across the rotor bars.

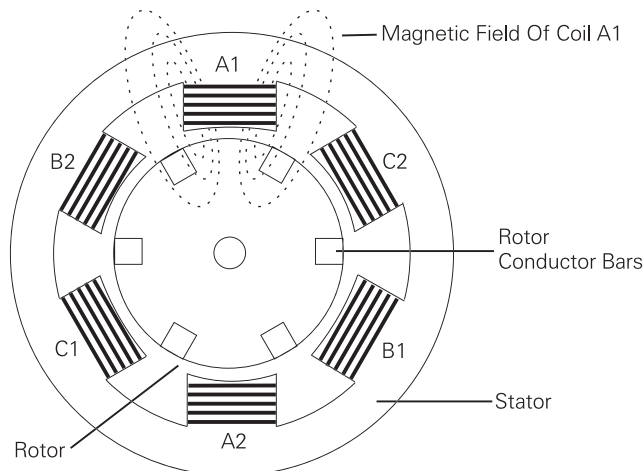

When a conductor, such as a rotor bar, passes through a magnetic field a voltage (emf) is induced in the conductor. The induced voltage causes a current flow in the conductor. Current flows through the rotor bars and around the end ring. The current flow in the conductor bars produces magnetic fields around each rotor bar. Recall that in an AC circuit current continuously changes direction and amplitude. The resultant magnetic field of the stator and rotor continuously change. The squirrel cage rotor becomes an electromagnet with alternating north and south poles.

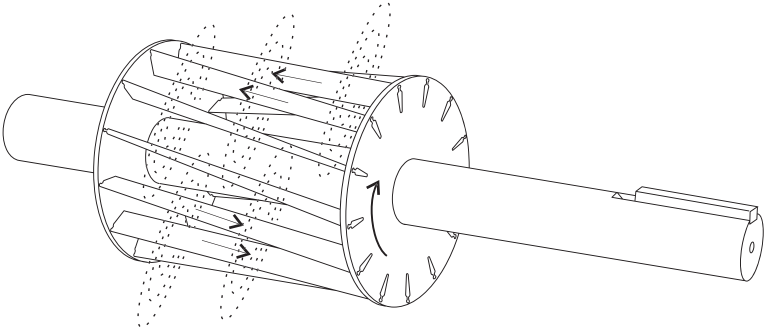

The following drawing illustrates one instant in time during which current flow through winding A1 produces a north pole. The expanding field cuts across an adjacent rotor bar, inducing a voltage. The resultant magnetic field in the rotor tooth produces a south pole. As the stator magnetic field rotates the rotor follows.

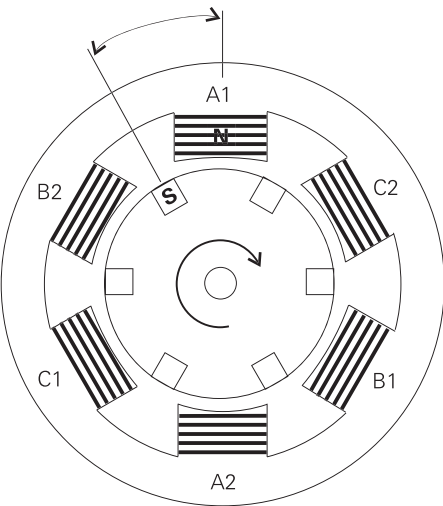

Slip

There must be a relative difference in speed between the rotor and the rotating magnetic field. If the rotor and the rotating magnetic field were turning at the same speed no relative motion would exist between the two, therefore no lines of flux would be cut, and no voltage would be induced in the rotor. The difference in speed is called slip. Slip is necessary to produce torque. Slip is dependent on load. An increase in load will cause the rotor to slow down or increase slip. A decrease in load will cause the rotor to speed up or decrease slip. Slip is expressed as a percentage and can be determined with the following formula.

$$\% \text{ Slip} = \frac{N_s - N_R}{N_s} \times 100$$

For example, a four-pole motor operated at 60 Hz has a synchronous speed (N_s) of 1800 RPM. If the rotor speed at full load is 1765 RPM (N_R), then slip is 1.9%.

$$\% \text{ Slip} = \frac{1800 - 1765}{1800} \times 100$$

$$\% \text{ Slip} = 1.9\%$$

Wound Rotor Motor

The discussion to this point has been centered on the more common squirrel cage rotor. Another type is the wound rotor. A major difference between the wound rotor motor and the squirrel cage rotor is the conductors of the wound rotor consist of wound coils instead of bars. These coils are connected through slip rings and brushes to external variable resistors. The rotating magnetic field induces a voltage in the rotor windings. Increasing the resistance of the rotor windings causes less current flow in the rotor windings, decreasing speed. Decreasing the resistance allows more current flow, speeding the motor up.

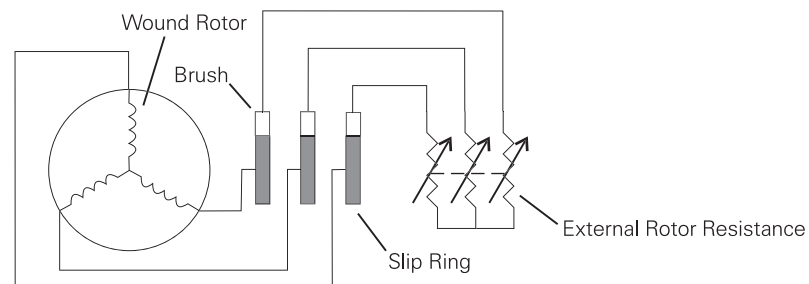

Synchronous Motor

Another type of AC motor is the synchronous motor. The synchronous motor is not an induction motor. One type of synchronous motor is constructed somewhat like a squirrel cage rotor. In addition to rotor bars coil windings are added. The coil windings are connected to an external DC power supply by slip rings and brushes. On start AC is applied to the stator and the synchronous motor starts like a squirrel cage rotor. DC is applied to the rotor coils after the motor reaches maximum speed. This produces a strong constant magnetic field in the rotor which locks in step with the rotating magnetic field. The rotor turns at the same speed as synchronous speed (speed of the rotating magnetic field). There is no slip. Variations of synchronous motors include a permanent magnet rotor. The rotor is a permanent magnet and an external DC source is not required. These are found on small horsepower synchronous motors.

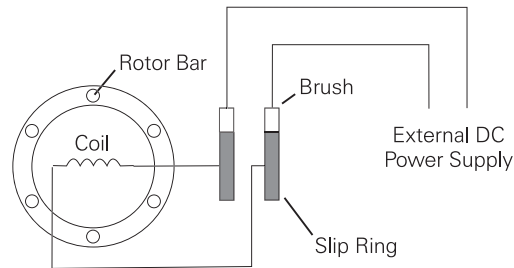

Review 4

1. The following illustration represents a _____ pole motor. If winding A1 is a south pole then winding A2 is a _____ pole.

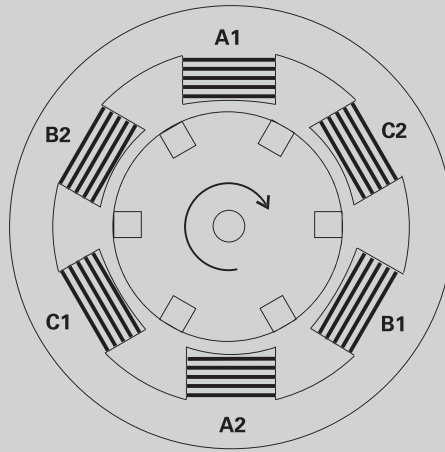

2. The speed of the rotating magnetic field is referred to as _____ speed.
3. The synchronous speed of a 60 Hz 4-pole motor is _____ RPM.
4. The difference in speed between the rotor and synchronous speed is _____ .
5. A 2-pole motor is operating on a 60 Hz power supply. The rotor is turning at 3450 RPM. Slip is _____ %.

Motor Specifications

Nameplate

The nameplate of a motor provides important information necessary for selection and application. The following drawing illustrates the nameplate of a sample 30 horsepower AC motor. Specifications are given for the load and operating conditions as well as motor protection and efficiency.

SIEMENS									
PE•21 PLUS™					PREMIUM EFFICIENCY				
ORD.NO.	1LA02864SE41				E NO.				
TYPE	RGZESD				FRAME	286T			
H. P.	30.00				SERVICE FACTOR	1.15		3 PH	
AMPS	34.9				VOLTS	460			
R.P.M.	1765				HERTZ	60			
DUTY	CONT 40 °C AMB.				DATE CODE				
CLASS INSUL	F	NEMA DESIGN	B	K.V.A. CODE	G	NEMA NOM. EFF.	93.6		
SH. END BRG.	50BC03JPP3				OPP. END BRG.	50BC03JPP3			
MILL AND CHEMICAL DUTY QUALITY INDUCTION MOTOR									
Siemens Energy & Automation, Inc. Little Rock, AR							MADE IN U.S.A.		

Voltage and Amps

AC motors are designed to operate at standard voltages and frequencies. This motor is designed for use on 460 VAC systems. Full-load current for this motor is 34.9 amps.

AMPS	34.9	VOLTS	460
------	------	-------	-----

RPM

Base speed is the nameplate speed, given in RPM, where the motor develops rated horsepower at rated voltage and frequency. It is an indication of how fast the output shaft will turn the connected equipment when fully loaded with proper voltage and frequency applied.

R.P.M.	1765	HERTZ	60
--------	------	-------	----

The base speed of this motor is 1765 RPM at 60 Hz. It is known that the synchronous speed of a 4-pole motor is 1800 RPM. When fully loaded there will be 1.9% slip. If the connected equipment is operating at less than full load, the output speed (RPM) will be slightly greater than nameplate.

$$\% \text{ Slip} = \frac{1800 - 1765}{1800} \times 100$$

$$\% \text{ Slip} = 1.9\%$$

Service Factor

A motor designed to operate at its nameplate horsepower rating has a service factor of 1.0. This means the motor can operate at 100% of its rated horsepower. Some applications may require a motor to exceed the rated horsepower. In these cases a motor with a service factor of 1.15 can be specified. The service factor is a multiplier that may be applied to the rated power. A 1.15 service factor motor can be operated 15% higher than the motor's nameplate horsepower. The 30 HP motor with a 1.15 service factor, for example, can be operated at 34.5 HP. It should be noted that any motor operating continuously at a service factor greater than 1 will have a reduced life expectancy compared to operating it at its rated horsepower. In addition, performance characteristics, such as full load RPM and full load current, will be affected.

SERVICE FACTOR	1.15
----------------	------

Class Insulation

The National Electrical Manufacturers Association (NEMA) has established insulation classes to meet motor temperature requirements found in different operating environments. The four insulation classes are A, B, F, and H. Class F is commonly used. Class A is seldom used. Before a motor is started, its windings are at the temperature of the surrounding air. This is known as ambient temperature. NEMA has standardized on an ambient temperature of 40° C, or 104° F within a defined altitude range for all motor classes.

DUTY	CONT	40° C AMB.
CLASS INSUL	F	

Temperature will rise in the motor as soon as it is started. Each insulation class has a specified allowable temperature rise. The combination of ambient temperature and allowed temperature rise equals the maximum winding temperature in a motor. A motor with Class F insulation, for example, has a maximum temperature rise of 105° C when operated at a 1.0 service factor. The maximum winding temperature is 145° C (40° ambient plus 105° rise). A margin is allowed to provide for a point at the center of the motor's windings where the temperature is higher. This is referred to as the motor's hot spot.

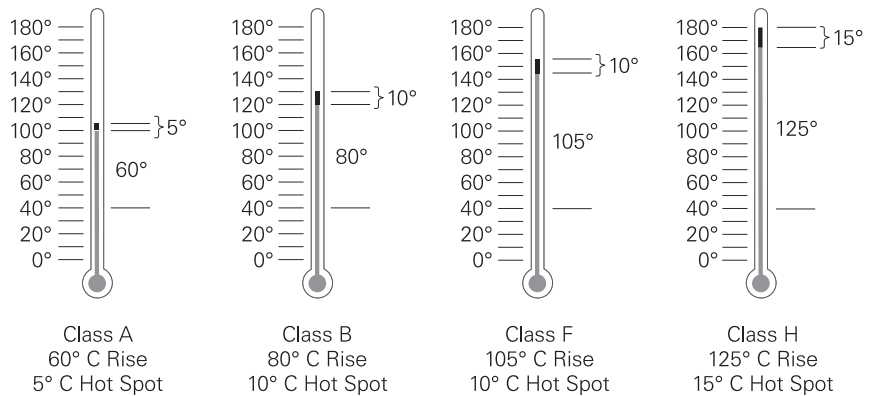

The operating temperature of a motor is important to efficient operation and long life. Operating a motor above the limits of the insulation class reduces the motor's life expectancy. A 10° C increase in the operating temperature can decrease the motor's insulation life expectancy as much as 50%.

Motor Design

The National Electrical Manufacturers Association (NEMA) has established standards for motor construction and performance. NEMA design B motors are most commonly used.

NEMA DESIGN	B
----------------	---

Efficiency

AC motor efficiency is expressed as a percentage. It is an indication of how much input electrical energy is converted to output mechanical energy. The nominal efficiency of this motor is 93.6%. The higher the percentage the more efficiently the motor converts the incoming electrical power to mechanical horsepower. A 30 HP motor with a 93.6% efficiency would consume less energy than a 30 HP motor with an efficiency rating of 83%. This can mean a significant savings in energy cost. Lower operating temperature, longer life, and lower noise levels are typical benefits of high efficiency motors.

NEMA. NOM. EFF	93.6
-------------------	------

NEMA Motor Characteristics

Standard Motor Designs

Motors are designed with certain speed-torque characteristics to match speed-torque requirements of various loads. The four standard NEMA designs are NEMA A, NEMA B, NEMA C, and NEMA D. NEMA A is not used very often. NEMA B is most commonly used. NEMA C and NEMA D are used for specialized applications. A motor must be able to develop enough torque to start, accelerate and operate a load at rated speed. Using the sample 30 HP, 1765 RPM motor discussed previously, torque can be calculated by transposing the formula for horsepower.

$$HP = \frac{T \times RPM}{5250}$$

$$T = \frac{HP \times 5250}{RPM} \quad T = \frac{30 \times 5250}{1765} \quad T = 89.2 \text{ Lb-Ft}$$

Speed-Torque Curve for NEMA B Motor

A graph, like the one shown below, shows the relationship between speed and torque the motor produces from the moment of start until the motor reaches full-load torque at rated speed. This graph represents a NEMA B motor.

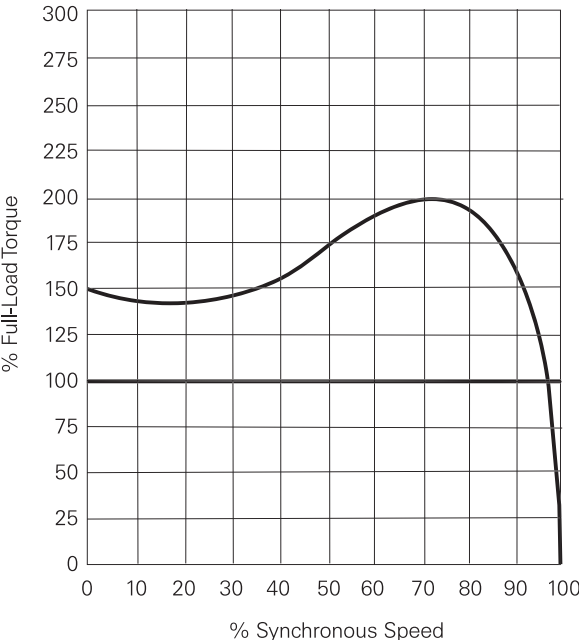

Starting Torque

Starting torque (point A on the graph) is also referred to as locked rotor torque. This torque is developed when the rotor is held at rest with rated voltage and frequency applied. This condition occurs each time a motor is started. When rated voltage and frequency are applied to the stator there is a brief amount of time before the rotor turns. At this instant a NEMA B motor develops approximately 150% of its full-load torque. A 30 HP, 1765 RPM motor, for example, will develop approximately 133.8 Lb-Ft of torque.

